

"The DockSider"™

Patented

Assembly, Installation, Setup, and Operating Instruction

OM CR300 - 072121



- ShoreMaster Canoe Rack; Series 300 -

- Holds Canoes up to 100 pounds.
- For ShoreMaster Infinity Docks RS4 and RS7
- Mounts to the Dock Siderail
- ShoreMaster Connectors (qty 2) must be purchased from your ShoreMaster Dealer prior to installation.
- Tools are required (7/16 & 9/16) Open End Wrenches) for initial installation.

**Some
Assembly
Required**

A Canoe Lift and Dock Storage Rack

Model CDR 300 - Shore Master Mount

- Holds your Canoe 5 to 17 inches below the dock surface.
- Includes a Pulley System which reduces the Pull required up to lift
- Accommodates Freeboard (Dock Surface to Water Level) height up to 30 inches.

Please read these instructions carefully before using this product and save this manual for future use.

For assistance, please call: 585 - 734 - 7374
Or send email to: info@DockCraft.com

**DockCraft Industries LLCSM
3694 Nibawauka Beach
Canandaigua, New York 14424**

Table of Contents

	Page
“The DockSider”™	
○ Safeguards	2
○ Warranty	3
○ Part List	3
○ Assembly Instructions	4
○ Dock Mount Installation	7
○ Installation- CR 300 Cradle Assembly	8
○ Setup	10
○ Operation	11

IMPORTANT SAFEGUARDS

1. **READ ALL INSTRUCTIONS BEFORE USING THE “The DockSider”™.**
2. The intended use of the product is to store a canoe on the side of a boat dock. Do not use this product for other than its intended use.
3. The maximum weight of canoe to be racked in “The DockSider”™ shall not exceed 100 pounds.
4. “The DockSider”™ is not intended for Salt Water applications unless you wash it off with fresh water occasionally.
5. Canoes **should not** contain more than one quarter inch (1/4”) of water inside when storing in the “The DockSider”™. Product Damage could result to the “The DockSider”™, if this is not followed the Warranty will be voided. If your Canoe contains excess amounts of water (capsized or other), roll canoe over to empty.
6. To ensure proper use, do not attempt to modify this product in any manner. Please refer to the manual if questions arise.
7. If further assistance is needed, please contact DockCraft Industries prior to use.
8. Do not allow children or adults to lean on, play on, around, or with the “The DockSider”™ while a Canoe is loaded or unloaded. Serious injury or damage to product, docks, and people could result if this warning is not followed.
9. Store only one Canoe per “The DockSider”™.
10. If the DockSider is not working properly, please contact DockCraft Industries immediately for assistance.
11. Do not enter or exit your Canoe when your canoe is engaged within “The DockSider” ; in the loading or storage position.
12. Do not install your Canoe Storage Rack such that “The DockSider” is near or in contact with any electrical or Dock Structural components.

Limited Warranty

What does your warranty cover?

- Any defect in materials or workmanship when used for the intended purpose of storing a canoe on the side of a boat dock under normal use and conditions.
- The warranty is limited to the original purchaser.

For how long after the original purchase?

- One year

What will we do?

- Provide you with a replacement part at no charge for any part found defective in materials or workmanship.

How do you make a warranty claim?

- Please contact DockCraft Industries for a Return Material Authorization (RMA) number before returning items. A shipping address will be provided at that time.

What does your warranty not cover?

- Damage from failures that occur as a result of improper assembly, failure to properly adjust and operate, misuse or neglect of product's intended purpose.
- Product which has been modified in any manner.
- Safeguards are not followed
- The warranty is not valid if you are not the original purchaser.

"The DockSider"TM PARTS LIST - **Canoe Lift & Storage Rack; Series 300**

Remove all parts from the box and remove the dock mount from the pivot lateral by unwrapping the mini wrap.

If any parts are missing from the package (in type or quantity), do not assemble and contact DockCraft Industries immediately.

Model CDR 300 -

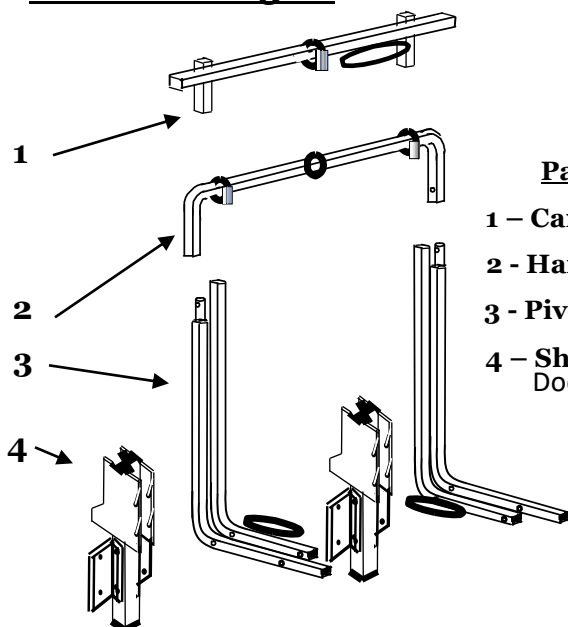

Parts Diagram

- 1 – Canoe Lifting System**
- 2 - Handle Assembly (1)**
- 3 - Pivot Lateral Cradle Assembly (2)**
- 4 – Shore Master Mount Set**
Dock Mount Brackets (2), Mounting Angles, Screws

Assembly Instruction

Attach Cradle Handle :

- 1 - Position Handle over Cradle.
 - 2 - Slide the Handle over extension on Cradle.
 - 3 - Depress Snap Button on Cradle.
 - 4 - Seat Handle until Snap Button pops through the Handle hole.
- 5 - Repeat process for the other side of the Cradle.

Steps 1 – 4

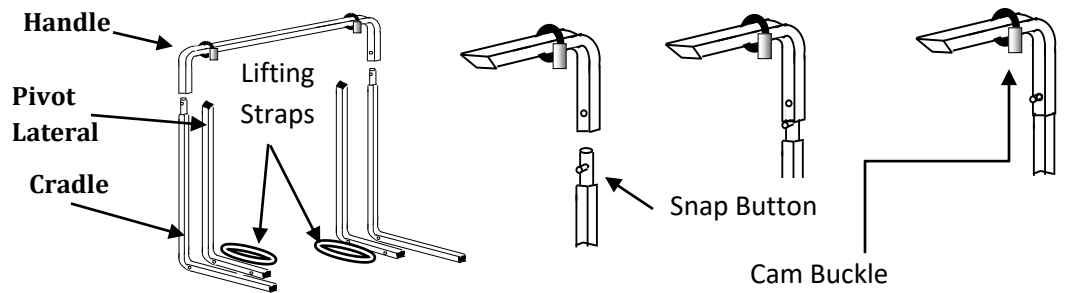

Canoe Rack

Notes - Canoe Rack – Shorter Legs on the inside

Insert Clevis Pins to set height of rack from water

If the Water Level is 10 to 25 inches below your Dock Decking -

- 6 - Insert Clevis Pin through Hole #2 in Pivot Lateral such that the head is between the Pivot Lateral and Cradle, attach retaining ring through the hole in the end of the clevis pin.
- 7 - If the Water Level is 25 inches or greater from the Dock Decking -
Insert Clevis Pin through Hole #4 in Pivot Lateral such that the head is between the Pivot Lateral and Cradle, attach retaining ring through the hole in the end of the clevis pin.

Canoe Rack

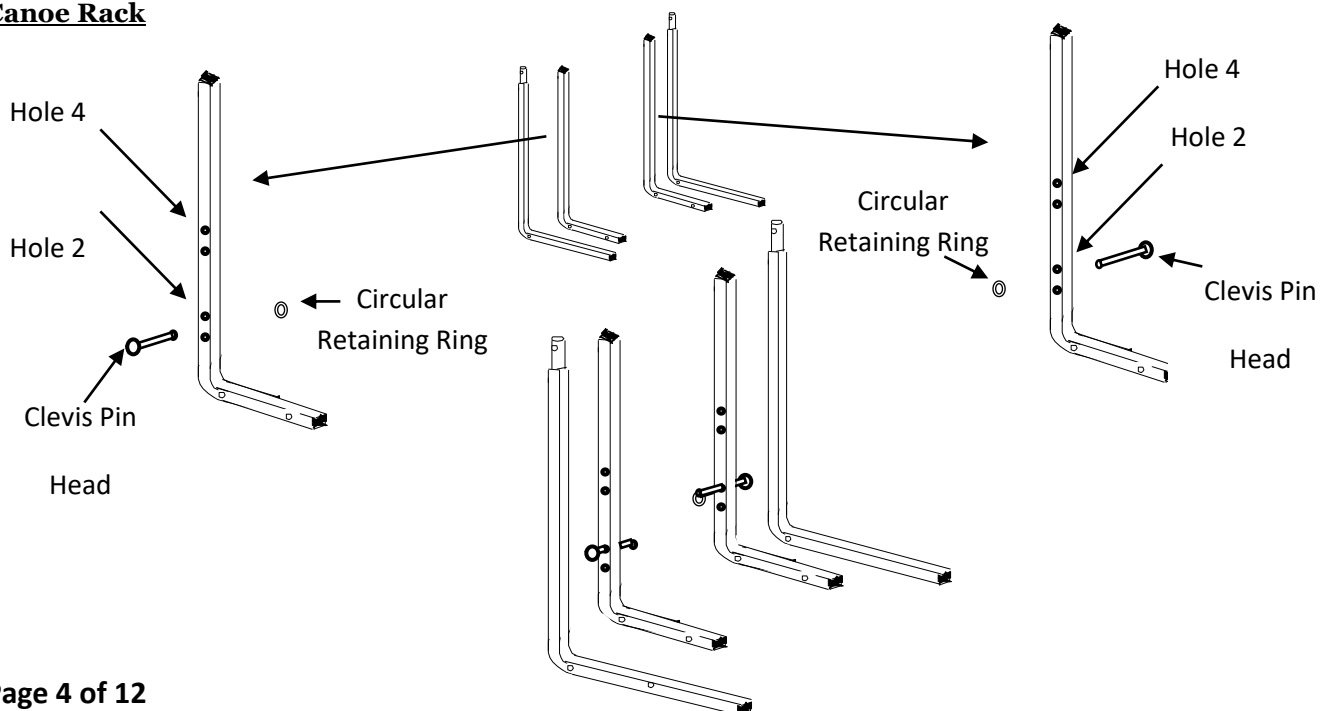

Thread Webbing through Cam Buckle :

8 – Obtain one of the Cam Buckles and Depress Lever

9 – Thread Webbing through opening in the Cam Buckle

Ensure the Slide on the Web Keeper is positioned as shown; ***Facing up and the webbing is not twisted.***

10 – Pull webbing through the Cam Buckle until the pre-marked line is in position with the cam buckle.

11 – Repeat Steps 6 – 8 to thread the webbing through the other Cam Buckle.

Steps 8 - 11

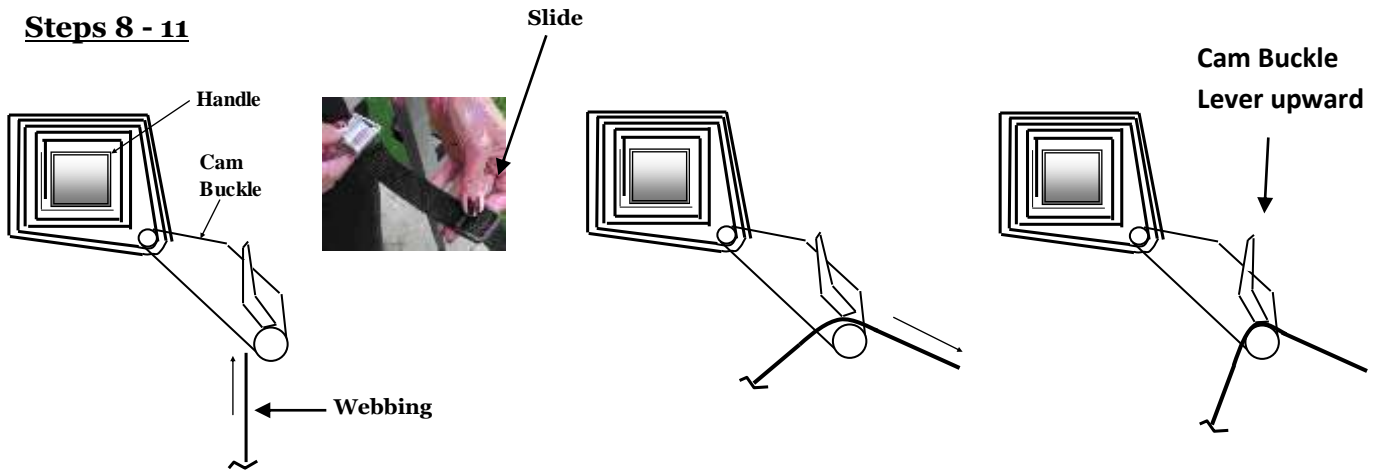

Assemble the Lifting Assembly to the Rack Assembly

Start by assembling the pulley to the webbing strap in the middle of the lifting assembly:

Remove the wing nut and push the screw so that it clears the side plate,

Rotate the side plate such that the nylon spacer and screw is exposed.

Slide the round spacer behind the webbing strap on the cross bar. Rotate the side plate back in position, push the screw through the hole and secure with the wing nut.

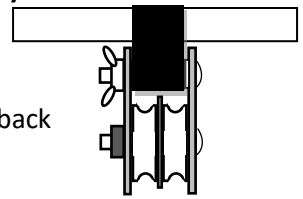

Remove mini wrap and rotate channels as shown

Snap buttons on this end

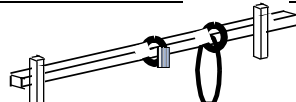
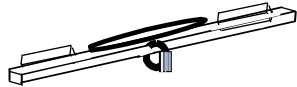

Align Lifting Assembly with Pivot Laterals, depress Snap Buttons and seat

Completed Assembly

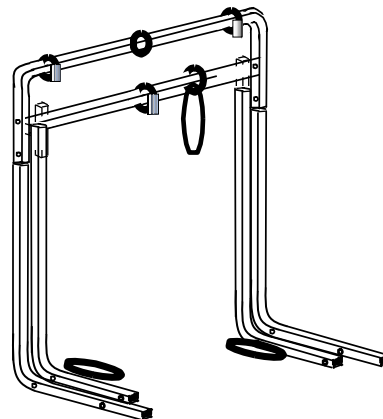
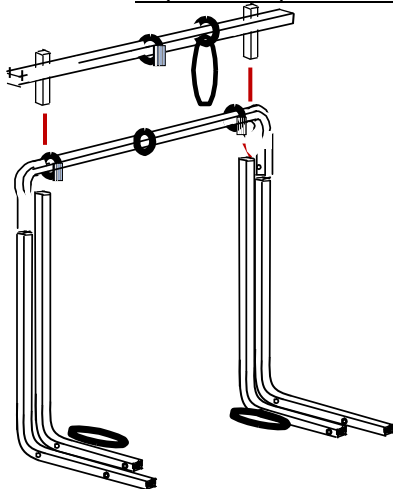

Assembly Instructions – continued

Attach the rope to the Pulley System. This Can be done now or after the unit is assembled to the dock.

Get the rope and tie two half knot next to the pulley assembly on the cradle handle.

The knot should be on the side of the pulley handle that has the head of the screw mounting the pulleys.

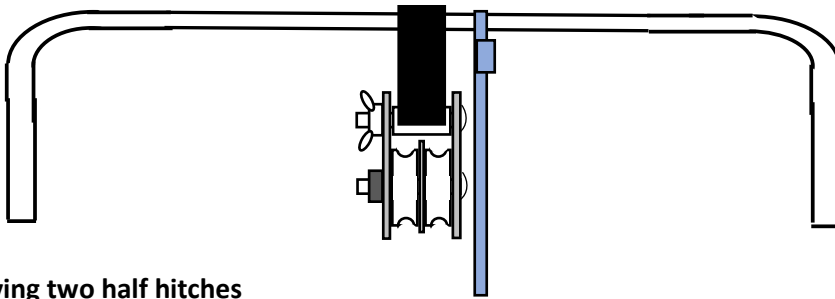

Tying two half hitches

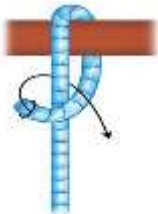

Wrap the rope
Around the cradle handle

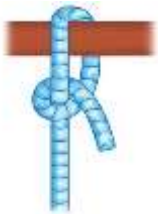

Pass the end
Through the loop

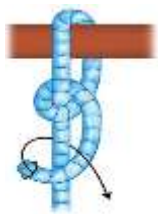

Wrap it around
the standing part



Tighten to
Complete

Tying a overhand knot on the loose end will give added security.



Thread the Pulleys

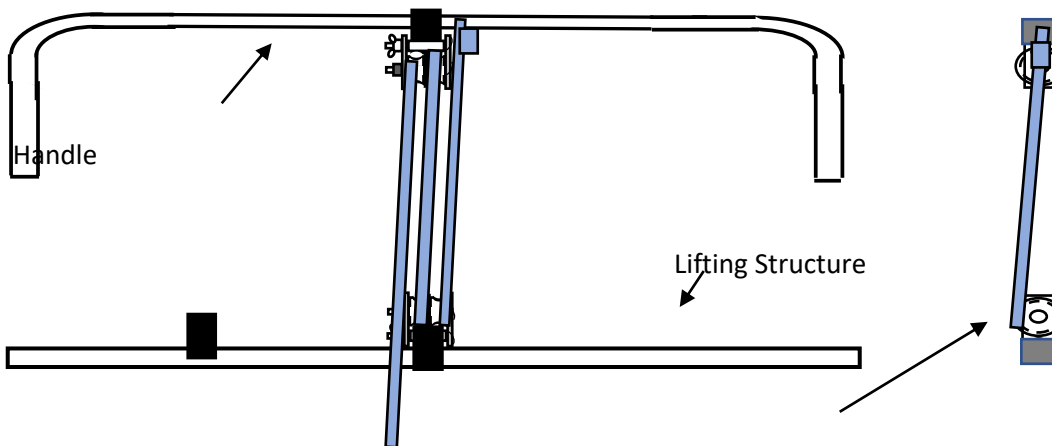

Slide knot next to pulleys, and thread Rope should be on top of pulley on Lifting Structure side,

When complete, coil the rope and secure it to the Lifting Structure with the Velcro strap.



Shore Master Mount Installation

With the Purchase the Series 300 ShoreMaster Mount
With your Lift and Dock Storage Rack

You also have to purchase the ShoreMaster
Connector (Qty 2) from you ShoreMaster Dealer

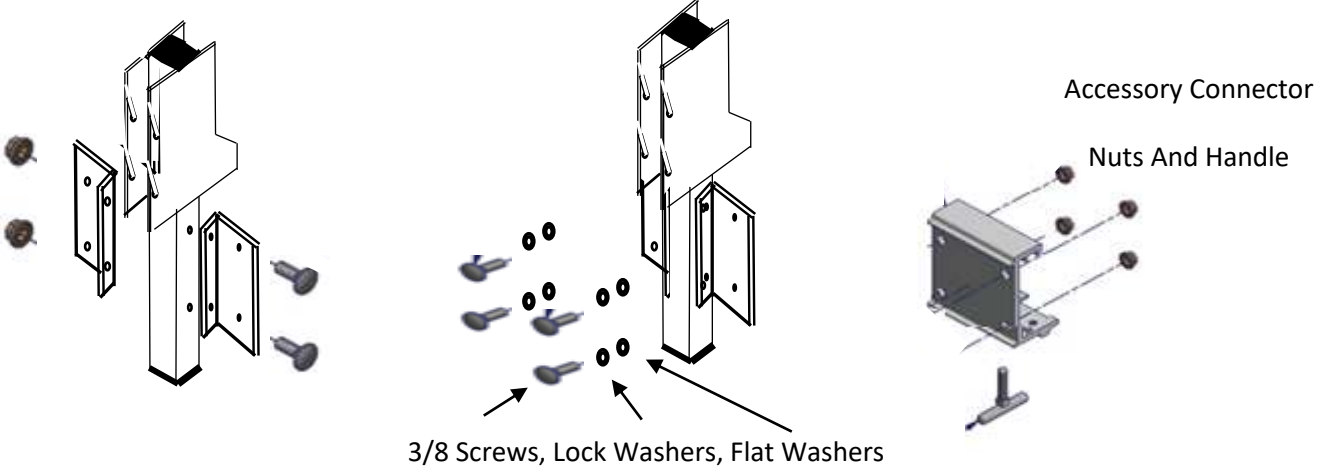

You get the Mount, Mounting Angles, and Hardware
Qty 2 sets

You get, the Connector,
and Hardware (Do not use Screws provided)

With the hardware provided (1/4 – 20 Screws and Flange Nuts) mount the mounting angles to the Mount.



Then attach the mount from above to the RS 4 or 7 (depending on your Infinity Dock) – Accessory Bracket with the hardware provided to the Accessory Connector purchased from your ShoreMaster Dealer.

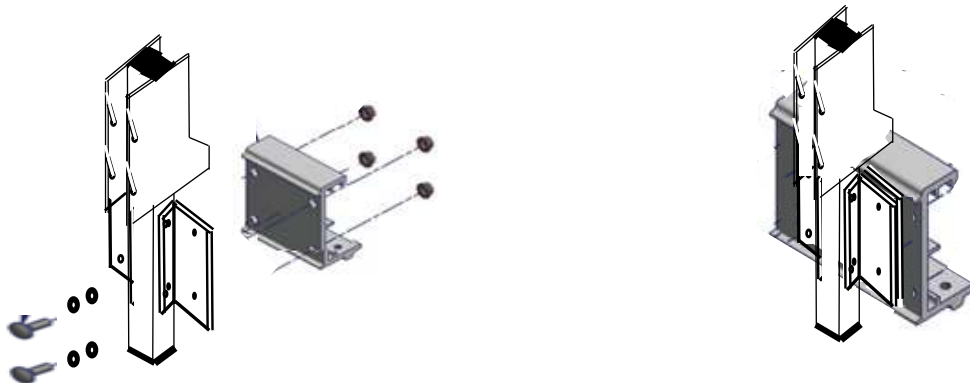

Insert the Lock Washer then Flat Washer on the Screw, then insert the screw through the mounting angle and Connector Bracket and secure with Flange nut provided with the Connector Bracket. 4 places. Assure that the Mount is perpendicular to the connector.

Shore Mater Mount installation - continued

Once the mounts (qty. 2) are assembled, you are ready to mount to your dock.
Mounting illustration does not show the mounts attached to the Connector.

Install both mounts on your ShoreMaster dock as follows:

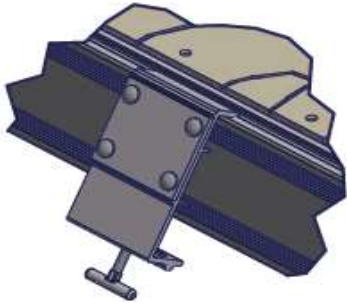

Pivot the top lip of the Accessory Connector Bracket assembly into the Groove on the top of the dock frame - as shown.

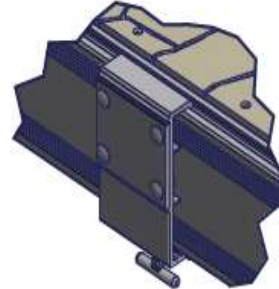

Once the Accessory Connector Bracket assembly is in the desired place, tighten the 2 1/2 - 3/8 x 1 1/2 T-Handle - as shown.

Note: Be sure to avoid the access holes on the bottom of the dock frame when tightening the T – Handle

Position the Dock Mounts on your Dock and Secure with T Handle



When mounted, the distance between mounts should be,

- Canoe Unit - 26 ½ inches apart (center to center)

Installation Procedure for Your - CR 300 Docksider

Canoe Storage Rack to Water Level Adjustment:

Now that the Mounts are in place; Mount the Cradle Assembly to them.

If the distance to the water from the dock decking is:

10 to 22 inches: insert clevis pin in the 2nd hole of the pivot lateral into the top Slot of the mounting bracket.

17 to 29 inches: insert clevis pin in the 2nd hole of the pivot lateral into the bottom Slot of the mounting bracket

20 to 31 inches: insert clevis pin in the 4th hole of the pivot lateral into the top Slot of the mounting bracket

25 to 37 inches: insert clevis pin in 4th hole of the pivot lateral into the bottom Slot of the mounting bracket

Adjust if required - up or down - based on your specific watercraft or if your water level changes significantly throughout the season.

Water Level Adjustment - Continued

To “Lock” the Brackets and Pivot Laterals together insert “Locking Pin” on both sides of unit.

If Clevis Pin with Circular Retaining Ring in Hole 2 or 4 of Pivot Lateral is seated in the **Top Slot**.



Insert 2nd Clevis Pin through hole in bracket
and secure with
“R” Retaining Clip on opposite side.



If Clevis Pin with Circular Retaining Ring in Hole 2 or 4 of Pivot Lateral is seated in the **Bottom Slot**



Insert 2nd Clevis Pin through hole in bracket
and secure with
“R” Retaining Clip on opposite side.



CR 300

Installation is complete

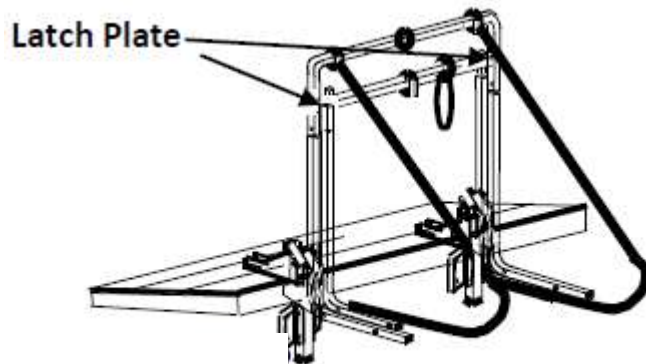

Rotate Latch Plates on lift Assembly side of unit.

SETUP of "The DockSider"™

Now that the installation is complete, it is now time to SETUP your Canoe Rack to "fit" your Canoe.

Webbing Length Adjustment :

As a result of the assembly procedure, the mark on the webbing should be located at the cam buckle.

This setting is a nominal setting for canoes with a width of 27 to 29 inches. Based on the width and contour of your canoe, this setting may vary. When loading, with the canoe in the water, the handle should be a couple of inches above the outside edge of the canoe.

This setting is for 2 purposes:

- 1 - To accommodate the size and contour of your Canoe
- 2 - To allow your Canoe to sit at an angle to minimize rain entering the Canoe and therefore collect in the cockpit

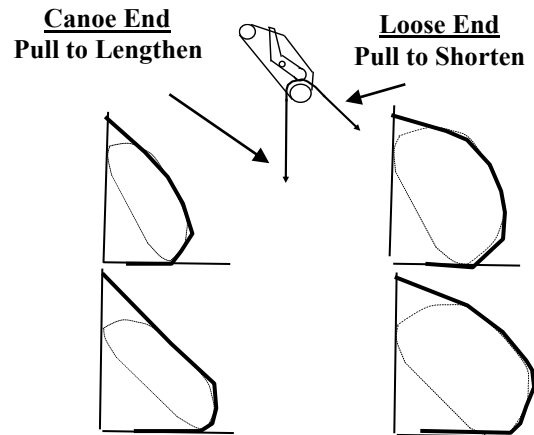

- 3 - Load your Canoe into your rack and rotate to the Canoe Storage Position by:
 - a: Rotating the Cradle toward the water such that the handle is parallel with the water. Do this using the lifting strap.
 - b: Floating your Canoe into the rack (between the handle and the webbing) such that the canoe is centered.
 - c: Lift your canoe just out of the water. If your canoe wants to lean to the right or left, check the straps to see if there is an excessive amount of strap on the side that's leaning, if so shorten. Also, you may want to adjust the position of the canoe in the rack. If the lean is to the left, reposition the canoe slightly to the right to have the center of gravity positioned between the straps. Reposition the canoe to the left if the lean is to the right. Remember this positioning for normal operation.
 - d: Grasp the center of the cradle or use lifting strap and SLOWLY rotate the handle to the storage position. Rotate SLOWLY, to understand the "feel" of the lift when your canoe rotates toward the Dock. Rotate the Latch Plates (both sides) into position to maintain the position of the Canoe.

If your Canoe in it's storage position looks like :

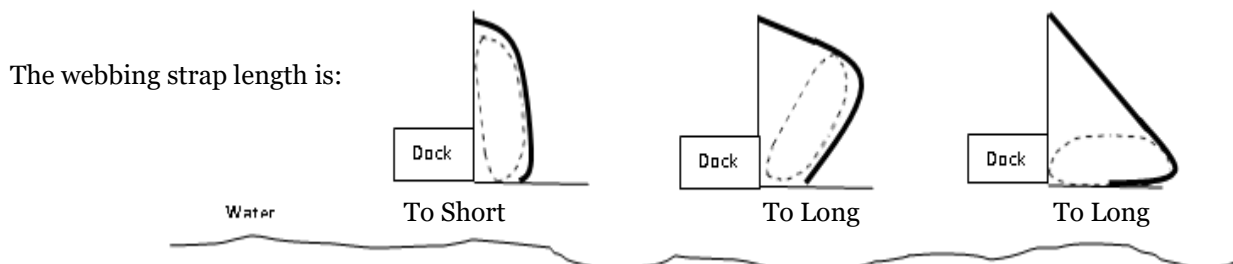

Note: If the dock surface to water height is between 10 and 15 inches, the figure above on the left maybe the best that can be achieved with the contour of your canoe.

To adjust the Length of the webbing straps:
Depress Cam Buckle lever and pull in the direction shown

Setup continued

The ideal storage position should look like:

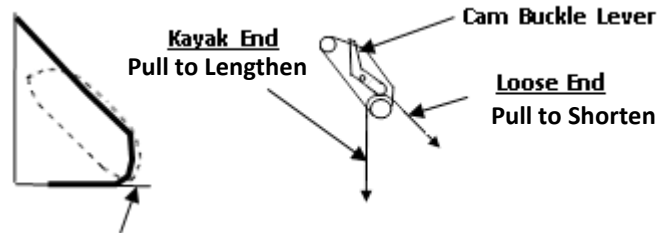

Never adjust such that the bottom of your Canoe is closer than 2 inches to the end of the cradle.
Note: the closer the canoe is to the end of the cradle, the greater the reach of operation.
Suggestion: If the Webbing length is too short, lengthen significantly.
Manually, position your canoe in the storage position at the desired angle, and then tighten straps by shortening.

Now that the webbing length is set, Secure Loose end of webbing length as follows:

Position the 1st Webbing Keeper approximately 12 to 15 inches down from the cradle handle; on each web strap.

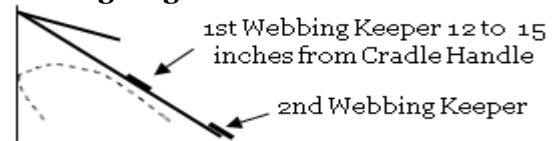

Thread the loose end of webbing through Webbing Keeper (each side of unit)

Cam Buckle Loose End of Webbing
Cam Buckle Canoe End of Webbing

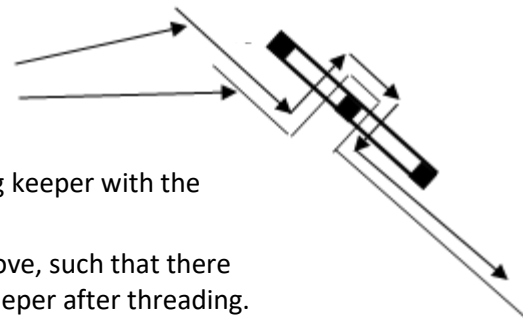

Note:
It is much easier to thread the webbing through the webbing keeper with the Canoe out of the Canoe Rack.
Reposition the 2nd webbing keeper and thread, similar to above, such that there is 1 to 3 inches of webbing extended beyond the webbing keeper after threading.
Reload your Canoe, and rotate your canoe into its storage position.

You may place your Paddle in the loop between the handle and the 1st webbing keeper.

The Setup is now Complete.

Operating Instructions

To UNLOAD: Note, if your paddle is stored in your Canoe Rack, remove your paddle first and set aside.

Canoe Operating Models

- 1 - Before unloading, check to Ensure that there are no objects or people in the path of the canoe when rotated toward the water.
- 2 - Standing on the Dock, grasp the pulley rope in one hand and then grasp the center of the handle.
- 3 - Rotate the Latch Plates on both Pivot Laterals 90 degrees counterclockwise. Note: Securely hold the handle as the Latch Plates are rotated out of the way, the weight of the Canoe will cause the Canoe Rack to want to rotate toward the water.

Operating Instructions – continued

- 4 - Firmly holding the pulley rope, slowly lower the canoe into the water, by releasing (hand over hand) the length of the tether cord until your canoe is in the water.
- 5 - Secure the end of the pulley rope that is left in your hand around the cross bar such that you may float your canoe out of the rack.
- 6 - Float your canoe completely out of the rack and then pull on the pulley rope, to lift the cradle back into the storage position.
- 7 - Rotate the Latch Plates back into its holding position such that the cradle will not rotate back into the water when released.
- 8 – Enter your Canoe ensuring you are clear of the rack, grab your paddle and start your voyage.

To Load and Store:

Canoe Operating Models

- 1 - Exit your canoe assuring you are clear of the canoe rack.
- 2 – Release the Latch Plates and lower the cradle.
- 3 – Secure pulley rope to the cross bar such that your canoe will float into your rack between the handle and the lifting webbing.
- 4 - Float your canoe into the rack and position.
- 5 - Grasp the pulley rope and slowly lift / rotate your canoe and rack into its storage position.
- 6 - Grasp the handle of your rack, holding it in its storage position.
- 7 - Rotate the Latch Plates into position such that your canoe will not rotate back into the water.
- 8 - Release your hand from the cradle handle and coil and secure the pulley rope to the cross bar with the Velcro strap
- 9 - If you choose, store your paddle between the webbing under the cam buckle.

You're DONE - just Load / Latch / and walk away!

WE SINCERLY HOPE YOU ENJOY THE CONVENIENCE OF



“The DockSider”™

For assistance, please call: 585 – 734 – 7374
Or send email to: info@DockCraft.com

**DockCraft Industries LLC
3694 Nibawauka Beach
Canandaigua, New York 14424
www.DockCraft.com**